

# **Dry Icer**

## Operator's Manual

# Table of Contents

<b>Warning</b> .....	<b>3</b>
Important Safety Instructions: .....	3
<b>Safety Precautions</b> .....	<b>3</b>
<b>Technical Specifications</b> .....	<b>4</b>
<b>Technical Drawings</b> .....	<b>4</b>
<b>The Dry Icer</b> .....	<b>5</b>
The 'Dry Ice' Fogger Principal .....	5
<b>Warnings</b> .....	<b>5</b>
<b>Maintenance</b> .....	<b>6</b>
Solid Carbon Dioxide .....	6
<b>Guidance for Users</b> .....	<b>6</b>
<b>Warranty</b> .....	<b>7</b>
<b>Contact Information</b> .....	<b>7</b>

**Note: Please read entire manual before operating the Dry Icer**



## Warning

### Important Safety Instructions:

1. Do not remove the outer case.
2. Ensure that this unit is supplied by a grounded receptacle at all times. Failure to do so may result in serious injury.
3. Dry ice must not be stored in sealed containers: evaporating gas will lead to a pressure build-up and a risk of an explosion.
4. Never handle dry ice with bare hands. Thick gloves must be worn.
5. Unplug the Dry Icer machine when pouring water into the unit.
6. Do not swallow solid CO<sub>2</sub> (e.g. practical jokes with a piece of dry ice in a liquid to give a 'laboratory effect'). This may lead to severe internal injuries.
7. Eye protection must be worn.
8. Before breaking the dry ice with a hammer, cover the dry ice with a piece of cloth or place the block in a cloth bag. This will prevent fragments from flying.
9. Do not use in a very confined space (e.g. a room less than 10 square feet)

## Safety Precautions

1. Ensure that any operation of the machine is supervised by suitably trained and authorized personnel.
2. Do not modify the machine or use a machine which has been damaged in any way.
3. Protect the machine from direct weather effects and wet locations.
4. Do not continue to produce fog when visibility is reduced to 20" (50cm) or below.
5. Avoid directing fog output continuously at people, structures or objects within close proximity of the discharge nozzle.
6. Ensure that adequate exhausting arrangements are available in the event of an emergency.

# Technical Specifications

**Model:** Dry Icer  
**Part Number:** CLF 1810 Dry Icer / 120 Volt  
CLF 1815 Dry Icer / 240 Volt

**Length:** 21in 53.3cm  
**Width:** 13.9in 35.3cm  
**Height:** 20.8in 52.8cm

**Power Rating:** 120 Volt A.C. 50/60 Hz. 12 Amps.  
240 Volt A.C. 50/60 Hz. 6 Amps.

## Technical Drawings

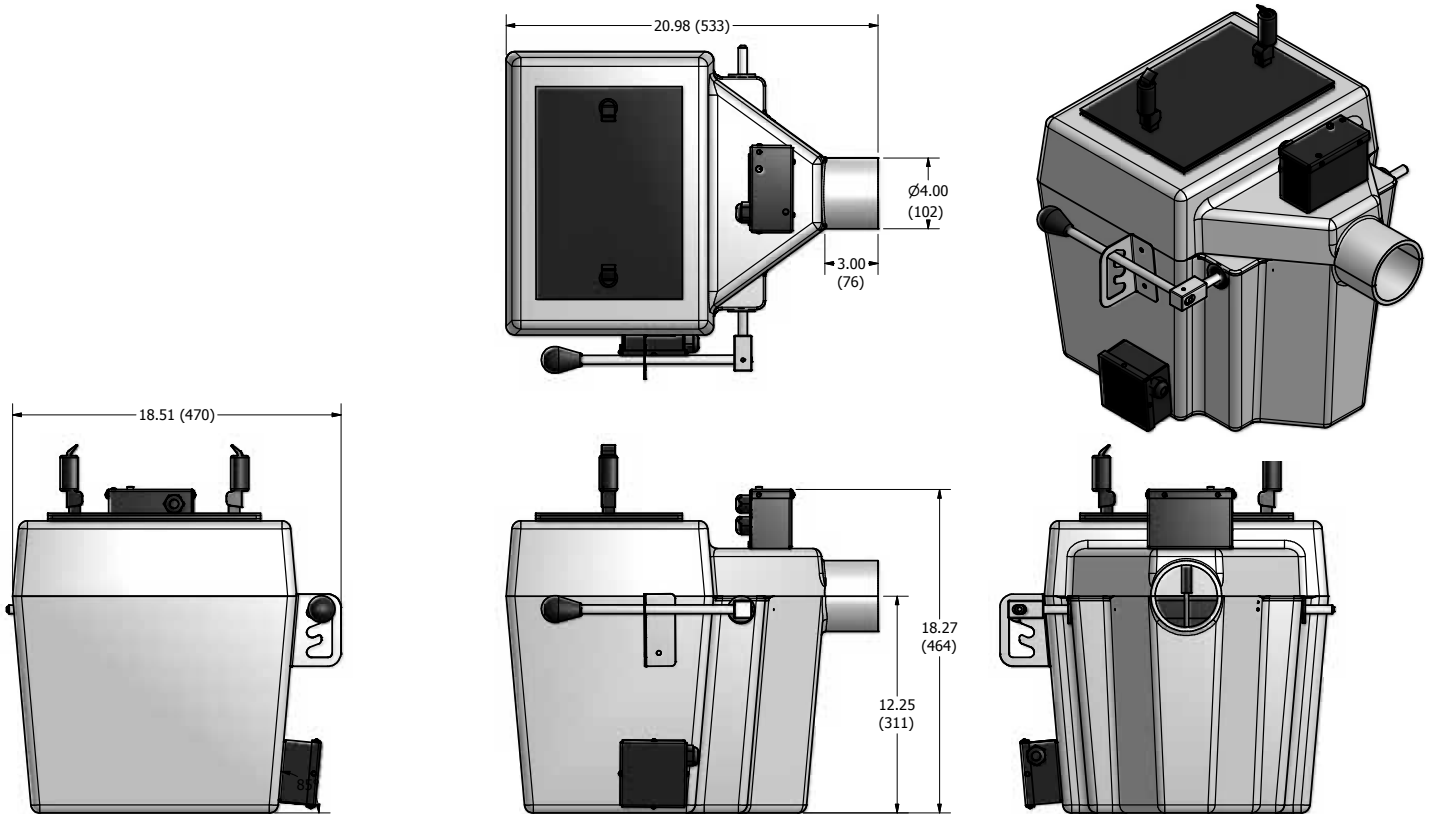

# The Dry Icer

The Dry Icer is compact and portable dry-ice fogger. It is made of a durable corrosion resistant polyethylene that will give trouble-free use while producing a thick white low-lying fog.

## The 'Dry Ice' Fogger Principal

'Dry-Ice' is a solid form of carbon dioxide (CO<sub>2</sub>). The term dry-ice is used because of its ability to sublime; the process of transforming from a solid directly to a gas without any liquid formation. Dry ice reaches a temperature of minus 87.5C. When immersed in hot or boiling water, it sublimates and violently agitates the water, which throws up many water droplets into the air. The released cold CO<sub>2</sub> gas causes the water vapor in the air to form more droplets. This great expansion of gas and moisture pushes its way out of the machine. Because it is cold it sinks to the floor. Due to the droplets in the air this creates the effect we see as fog.

## Operation

1. Place the machine on a firm level surface where it will be used. Take off the lid and fill with water (hot or cold) with about 5 gallons (20 litres) until the red light comes on.
2. Plug the cord into a grounded 15-amp receptacle. A ground fault interrupted receptacle would be preferred. The heater draws 12 amps at 120 volts.
3. While the machine is heating up (may take up to 60 minutes), raise the basket to its highest level with the black handle on the side of the machine and lock it in the highest stop.
4. When the water is steaming after approximately 45-60 minutes the machine is now ready for use.
5. Using protective gear load the basket with up to 20lbs of dry ice. The basket size has been designed to give one large 'show' from each bag or block of dry-ice if filled to approximately 1-1 ½ " from the basket rim. The loading of the dry-ice should be done at the last possible moment. Due to the steamy atmosphere in the machine, it will evaporate if put in too long beforehand.
6. Remove any ice chips on the lid seal and place the lid on. Secure the lid by turning the two arms inward on the lid and push down on the levers to latch.
7. When the 'fog' is required, grasp the basket lever and slowly lower the handle. A full basket should not be plunged into the hot water. This would result in dangerous pressure build up due to the violent action of the dry-ice sublimating. A ratchet stop is provided to allow the basket to be stepped into the water. As the CO<sub>2</sub> is immersed a 'fog' will be produced in thick clouds from the front nozzle. To increase the rate, lower the handle to the next stop. Raising the handle fully will quickly stop the effect, thus it is possible for an ON & OFF type of effect.
8. After your first effect top up the water and allow the unit to heat up. Take the CO<sub>2</sub> block/pieces from its storage container and load in the basket.
9. When the machine is to be emptied allow it to cool. Empty the machine into buckets where it stands rather than carrying it to the drain. Do not move the machine with hot or boiling water in it.

## Warnings

- Water temperature can reach boiling point therefore touching or spilling the hot water can result in burns.
- An overfilled machine will eject water. Never fill with unit plugged in.
- Moisture and water pose electrical hazards use caution around this equipment. Ground fault circuits will trip from excess moisture.
- Only handle dry-ice with proper skin and eye protection.

# Maintenance

1. Keeping lid screws lightly oiled will protect them allow them to operate easily.
2. Make sure no dry ice is on the rubber lid seal. This will allow gas escape through the lid gasket.
3. Do not pour cold water directly onto hot heater element as this will cause premature failure.
4. To replace the element or repairing a broken seal:
  - a. Remove element/ replace or clean.
  - b. Replace the rubber gaskets and sealing washers. Do not reuse the old ones.
  - c. Tighten bolts evenly to compress the seal.

## Solid Carbon Dioxide

The CO<sub>2</sub> should be collected as near as possible to the time it is to be used. It will sublime with time but storage in an insulated container will help. Your distributor may have storage containers available. A wooden box lined with foam insulated is acceptable. Blocks, slabs and pellets may be available depending on your supplier. The pellets are easier to use as they don't require breaking up. If a solid block is used, it must be broken up into small pieces preferably about 1" across. Slabs can be laid on a flat surface and broken like toffee! Cover the ice with a towel to reduce the danger of flying pieces while breaking.

## Guidance for Users

**General:** Carbon dioxide gas is released by immersing solid CO<sub>2</sub> into boiling water. In its natural state this gas is colorless but suspends water vapor when emitted from the machine giving the 'fog' effect. Although carbon dioxide is an inert gas, it does not sustain life (Because the gas is heavier than air and sinks there is no problem, although care must be taken to ensure nothing is below the 'fog' level, i.e. small pets, people lying down etc). CO<sub>2</sub> will dissipate very quickly. Remember the output of the machine creates humidity so do not use it in the vicinity of electrical equipment, power sockets, or any item that may be damaged by moisture. In any event do not use the machine in rooms smaller than 10 feet by 10 feet.

**Overfilling:** Many of the problems arise from putting too much water in the machine. There should be no water from the nozzle except from some condensation. If the water level is too high boiling water can be sprayed out when the dry ice is submerged, damaging floors or burning people.

# Warranty

<b>Warranty:</b>	Hardware products come with a one year warranty on parts and labor. Unless stated otherwise, this will refer to manufacturer defects only. All warranty is based on destination of the original sale. Any additional costs incurred are the responsibility of the Dealer and/ or the customer. Abuse or poor maintenance is not accepted. Proof of purchase or proof of sale must always accompany all warranty returns. An RA (Return Authorization) number must be noted on the outside of each box being returned to our facility. Any package(s) without an RA number clearly marked, will not be accepted by our receiving department. Freight on warranty items are freight prepaid to our facility and we will prepay freight back to your facility following repair. This will be done by the most economical means available. Should you require the item express-returned, the dealer is responsible for request indication and any difference in freight cost.  Export Distributors are required to carry out the warranty repair, parts will be supplied by Ultratec.
<b>Return Policy:</b>	Return of any product must be done within 30 days of purchase. The package must be returned freight prepaid and the RA number clearly marked on the outside of the box.
<b>Warning:</b>	Ultratec Special Effects considers all of it's product to be safe for use in the application it was intended. Ultratec Special Effects takes no responsibility for misuse or incorrect use. Always refer to the Product Manual for proper use.

---

## Contact Information

### Head Office

Ultratec Special Effects  
1960 Blue Heron Drive  
London, Ontario N6H 5L9

Direct: 519-659-7972  
Toll Free: 866-534-5557  
Fax: 519-659-7713

### Europe Office

Ultratec Special Effects GmbH  
Dieselstrasse 30-40  
60314  
Frankfurt am Main  
Germany

Direct: 49-69-87-000-1850  
Fax: 49-69-87-000-1899

### Canadian Shipping Address

(For All Canadian Repairs)  
Ultratec Special Effects  
1960 Blue Heron Drive  
London, Ontario N6H 5L9

### USA Shipping Address

(For All USA Repairs)  
Ultratec Special Effects  
640 Gadson Street  
Groveland, Florida 34736

Please remember to include the **RA Number on all items being shipped for repairs.**

To retrieve an RA Number visit [www.ultratecfx.com](http://www.ultratecfx.com) and click on the "Service" section. Then click on "Return Authorization Request" which is located on the left hand side of the page.

If you have any questions or require assistance please contact service at 519-951-3357/866-534-5557 or by email at [Service@Ultratecfx.com](mailto:Service@Ultratecfx.com).