

VL4000 Spot Luminaire



The VL4000 Spot includes all the tools needed to create dynamic and useful lighting on any stage. Every aspect of the luminaire has been designed with performance in mind. The 1200W VL4000 Spot boasts 33,000 lumens and features a quiet Studio mode outputting 25,000 lumens. High resolution optics ensure remarkable center-to-edge focusing and an unprecedented contrast ratio. A 5:1 zoom covers an amazing 9 to 47 degrees without sacrificing output or clarity.

Our engineers designed the entirely new Infinity color system that provides CYM color mixing, variable CTO color temperature correction and dual five-position color wheels. As a result, the luminaire has incredibly smooth color mixing whether operating in a slow fade or instant snap. The dual opposing fixed color wheels achieve unique color effects, providing a multitude of multi-color combinations.

The VL4000 Spot luminaire features dual rotating gobo wheels with a remarkable new collection of optimized gobo patterns for both aerial and projected imagery. Dual animation wheels provide dynamic motion effects as well as the chromatically tuned Dichro*Fusion effect. The beam can be further modified via the precise four blade shutter system and mechanical iris. An independent prism with divergence control and variable frost are also implemented into the luminaire.

Unbelievably smooth dimming flags combined with independent strobe blades deliver unmatched dimming and strobing abilities. New innovative electronics infrastructures and luminaire software enable the VL4000 Spot luminaire to outperform all other luminaires on multiple accounts. A battery-backed full color LCD display is designed to be intuitive and easy to use. New multi-point connections allow the luminaire to be hung at any angle, while a pocketed safety cable attachment trap effortlessly ensures added safety.

Programmable Functions

Color System:

A three filter CYM cross fading system capable of extremely smooth movements at both slow and fast speeds, and a variable CTO color temperature correction system.

Fixed Color Wheels:

Two opposing fixed color wheels each with five interchangeable color filters are capable of producing multi-color effects and variable wheel rotations.

Zoom Optics:

A 12-element 5:1 zoom optics system, covering a range from 9° to 47°.

Beam Size Control:

A mechanical iris provides continuous beam size control for rapid and smooth timed beam angle changes.

Shutter Control:

A four-blade shutter mechanism that allows the blades to be operated independently or in unison on two planes for a clear and crisp image. The entire mechanism can rotate 50° in either direction.

Rotating Gobo Wheels:

Two gobo wheels combine to offer seven rotatable, indexable gobo positions and one open position.

Animation Wheels:

Two animation wheels each offer unique rotatable, indexable patterns with variable motion control from horizontal to vertical. Unique Dichro*Fusion pattern is chromatically tuned to provide endless color effects.

Rotating Prism:

Independent rotating and indexing 3-facet prism with variable divergence control.

Edge and Pattern Focus:

Variable beam focus to soften edges of gobos or spots. Remarkable depth of field capability allows morphing effects between gobo and animation wheels.

Variable Frost:

Independent variable frost glass with adjustable softness control.

Intensity Control:

Full field dimming designed for smooth timed fades as well as quick dimming effects.

Strobe:

High-performance dual blade strobe system capable of ultra-fast operation.

Pan and Tilt:

Smooth, time-controlled continuous motion by way of three-phase stepper motor systems.

Range:

Pan - 540°, Tilt - 270°.

Accuracy:

0.1° resolution.

Description

Source:

1200W Philips MSR Gold FastFit

Color Temperature:

6000K

Fixture Output:

Standard Mode: 33,000 lumens
Studio Mode: 25,000 lumens

Reflector:

Precision glass reflector system with dichroic cold mirror coating.

Power Requirements:

Standard AC power distribution from 208 - 240VAC, 50/60 Hz. The unit requires up to 12.0 A depending on the AC supply voltage.

Menu System:

Full color LCD with battery powered control.

Operational Temperatures:

Standard Mode: -20° to 104°F (-29° to 40°C)
Studio Mode: -20° to 122°F (-29° to 50°C)

Cooling:

Forced air cooling.

DMX Control:

Completely compatible with a wide variety of DMX512 consoles.

DMX Channels:

57 Channels (Enhanced 16-Bit Mode) / 52 Channels (16-Bit Mode)

RDM Control:

Completely compatible with a wide variety of RDM devices.

Mounting Position:

The VL4000 Spot luminaire can be mounted and operated in any orientation and includes multiple mounting bracket options.

Spacing:

Hangs on 25 in. (63.5 cm) centers

Weight:

83 lbs (37.7 kg)

Ordering Information

Luminaires:

20.9704.0001

VL4000 Spot Luminaire, Black, Includes 1200W Short Arc Lamp

Accessories:

71.9704.1200
22.9620.0194
PEGASUS
55.6840.0001
55.6841.0001
PCT1BE
PCT1GTL208
PCT1GP

1200W Short Arc Lamp, Philips MSR Gold FastFit

Safety Cable Assembly

Luminaire Programming Kit

Truss Hook, Mega-Clamp (For round and square pipe)

Truss Hook, Mega-Claw (For 2" round pipe)

AC Input Cable, Neutrik® powerCON® True1 with Bare End (no connector), 1 Meter

AC Input Cable, Neutrik® powerCON® True1 with Twist Lock (Male), 250V, 1 Meter

AC Input Cable, Neutrik® powerCON® True1 with Stage Pin (Male), 1 Meter

PHILIPS

VARI*LITE

VL4000 Spot Luminaire

Specifications

The unit is an integrally designed, remote-controlled, motorized spot luminaire. The head, yoke and enclosure housings are constructed of aluminum alloy for light weight, strength and durability. Low-noise fans provide forced-air cooling for internal components. The rear cap provides easy access to the lamp for replacement. Oversized upper-enclosure handles allow for easier hanging and loading.

A single Neutrik® powerCON® True1 input connector along with two, five-pin DMX512 compatible connectors (in and through) are provided. The unit can be controlled from a wide variety of DMX512 consoles and also supports RDM. An integrated USB connector provides firmware update and diagnostic abilities.

Each unit is equipped with an on-board processor providing diagnostic and self-calibration functions as well as internal test routines and software update capabilities. A full color LCD menu system with battery operation provides luminaire feedback and manual options settings.

The unit includes integral pan and tilt locks.

The unit contains two independent three-phase stepper motors to provide movement of the head through 540° in the horizontal plane (pan) and 270° in the vertical plane (tilt). The pan and tilt mechanisms are belt-driven, providing positional resolution and repeatability of 0.1° on either axis.

A 5:1 zoom optics system adjusts the projected field angle over a range of 9° to 47°. Variable beam focus is provided to soften the edges of gobos or spots and to provide gobo morphing. The projected image remains in focus throughout the entire zoom range.

The unit contains a CYM color mixing system, as well as variable CTO color temperature correction.

Two color wheels capable of continuously spinning are also included. Each of the two wheels holds five interchangeable dichroic colors to allow for custom configurations. The unit comes equipped with a standard palette of dichroic color filters.

The fixture's shutter mechanism is comprised of four frame blades that move independently or in unison on two planes for a crisp, sharp image. The entire assembly operates in a smooth, time-continuous motion using stepper motors (two per frame blade and one for the entire mechanism). The shutter mechanism can rotate 50° in either direction and the frame blades can tilt +/- 30°.

Unit has two, seven-position gobo wheels. Each contains individually rotating, indexable gobos and patterned glass effects. The rotating gobos are easily interchangeable to allow customization of the unit. The unit comes equipped with a standard set of gobos and effects. (A wide selection of colored and patterned gobos and effects is available from Vari-Lite.)

Dual rotating, indexing animation wheels provide variable horizontal and vertical movement effects. The Dichro*Fusion effect provides chromatically tuned multi-color effects.

The unit contains an independent rotating and indexing 3-facet prism with variable deviation control.

The unit offers frost capability with an independent, drop-in armature that includes an adjustable frost level.

A mechanical iris provides continuous beam size control for rapid and smooth timed beam angle changes.

The unit contains a patterned glass dimmer system that provides full field dimming and allows for smooth timed fades and fast blackouts.

A dual blade strobe and dousing system provides variable strobe effects capable of rapid operation.

The unit shall be ETL and ETLc certified and CE-marked. Exterior finish is black.

Hanging Dimensions

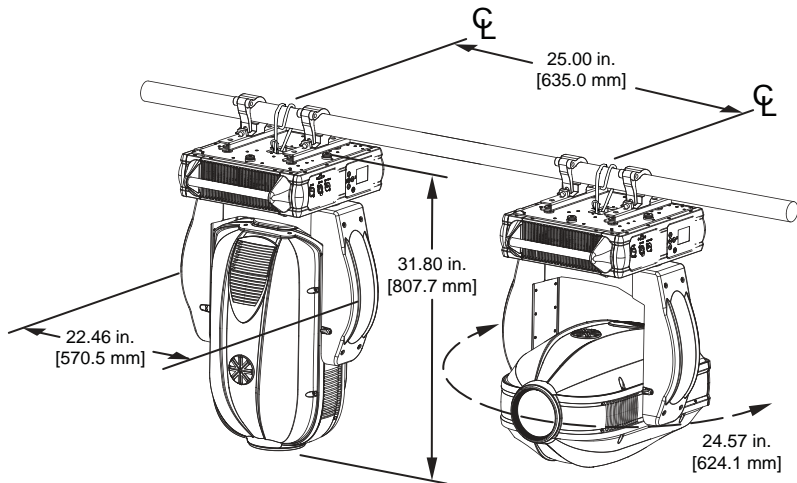

Note: Shown with optional safety cables, clamps, etc.

VL4000 Spot Luminaire - Lumen Output

VL4000 Spot Luminaire (Standard Mode):	33,000 Lumens
VL4000 Spot Luminaire (Studio Mode):	25,000 Lumens

Notes:

- * Values shown are preliminary data and subject to change.
- * Average lumens shown as measured with seasoned lamps with luminaires at full.

VL4000 Spot Luminaire - Gobos



VL4000 Spot Luminaire - Animation Wheels



PHILIPS
VARI*LITE

©2014 Philips Group. All rights reserved. Printed in the U.S.A. We reserve the right to change details of design, materials and finishes. Some features may be the result of future software updates. Specifications are subject to change without notice. VARI*LITE automated lighting equipment is made in the U.S.A.



Vari-Lite
10911 Petal Street
Dallas, TX 75238
1.877.VARILITE
fax: 214.647.8038
www.vari-lite.com



VL4000_Spot - 060214_NA_EUA