

Stage Fogger DMX Operations Manual



Table of Contents

Page 1	Introduction
Page 2	Warning
Page 3	Safety Precautions
Page 4	Technical Specifications
Page 5	Operating Procedure
Page 6	Remote Handset Operations
Page 6	DMX Control Procedure
Page 7	Remote Handset Image
Page 7	DMX Control Image
Page 8	Stage Fogger DMX Tube Change Procedure Images
Page 9	Stage Fogger DMX Tube Change Procedure
Page 11	Recommended Fluids
Page 12	Warranty

Please Read Carefully Before Operating

Introduction

The Stage Fogger DMX is a Microprocessor Controlled, Water Base Fog generating system.

Microprocessor Control

The Microprocessor is responsible for the following control elements -

- Monitoring the heat exchanger temperature.
- Driving the heater within the heat-exchanger.
- Driving the fluid pump unit, relating fluid flow to temperature
- Accepting and manipulating data from the Flow Input.
- Accepting data from the Smoke Switch.
- Ready Status, Heater Status, temperature .

Water Base Fog Technology

Water Base Fog technology is achieved by pumping a Glycol/Water mixture through a Heat exchanger. The heat exchanger has been heated to the point where at the fog fluid mixture will vaporize.

The fluids own vaporization forces the hot mixture out of the output nozzle where, when it mixes with the ambient air, it forms an opaque aerosol (fog). The fog is made up of tiny droplets of glycol that form around the small particles in the air. The suspended droplets reflect the light, which is why fog will take on the colour of the light illuminating it.

Warning



Important Safety Instructions: Do not touch or place hands, expose skins, within 50 cm. of discharge nozzle.



Important Safety Instructions: Do not remove the outer case until power has been disconnected from the machine.



Important Safety Instructions: Persons suffering from asthma or allergenic sensitivity may experience irritation, discomfort, or allergic symptoms when exposed to fog effects.



Important Safety Instructions: Ensure that this unit is grounded at all times. Failure to do so may result in serious injury.



Important Safety Instructions: Never use alternative fluids. Toxicity free output is your responsibility.

M.S.D.S. available at www.lemaitrefx.com

Safety Precautions

1. Ensure that operation of the machine is supervised by suitably trained and authorised personnel.
2. Do not modify the machine or use a machine which has been damaged in any way.
3. Allow sufficient air circulation around the machine at all times.
4. Protect the Stage Fogger DMX from direct weather effects and wet locations.
5. Only use fluids recommended by the Le Maitre Special Effects.
6. Do not continue to produce Fog output in an enclosed area when visibility is reduced below 50cm.
7. Avoid direct Fog output continuously at persons, structure or objects within close proximity of the discharge nozzle.
8. Ensure that adequate exhausting arrangements are available in the event of an emergency.
9. Do not place hands, or exposed skin within the first 50cm of the discharge nozzle at any time during fog production.
10. Fog effects can trigger smoke alarms and detectors. Please take suitable precautions to prevent false alarms.

Technical Specifications

Model:	Stage Fogger DMX	
Type:	Water Base Fog generating system	
Size:	Height: 10 3/4" 27.3 cm. Width: 10 3/8" 26.3 cm. Length: 25 1/2" 63.5 cm.	
Net Weight:	13.6 Kg.	30 lbs.
Weight With Fluid	17.7 Kg.	39 lbs.
Power Rating:	110 Volt A.C. 50/60 Hz	13 Amps
	240 Volt A.C. 50/60 Hz	6.5 Amps
Included:	Full Timer Remote RCT Replacement Kit On-Board DMX	

Stage Fogger DMX

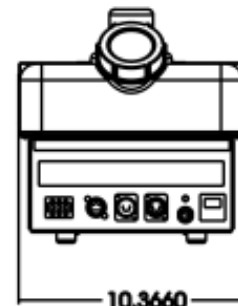
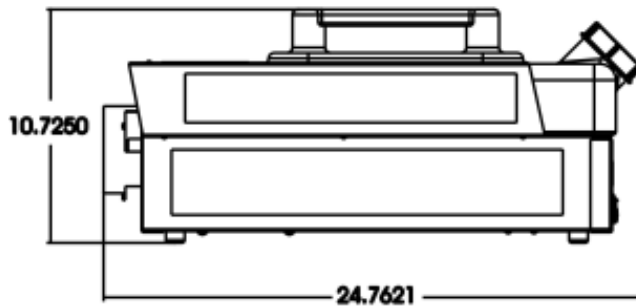
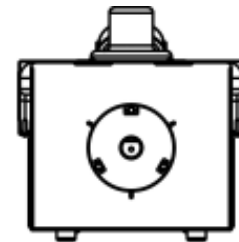
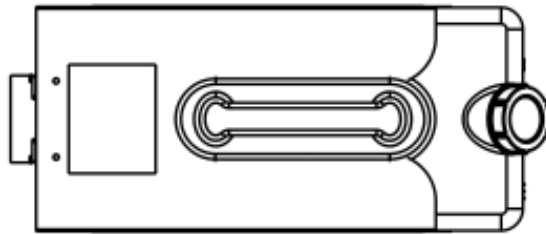

Operating Procedure

- 1) The Stage Fogger DMX must only be connected to a grounded mains supply capable of sustaining at least 15 Amps. The supply should be 'clean' and free of interference.
- 2) Open a container of Le Maitre fog fluid, remove cap and break foil seal (if provided). Remove Cap from Stage Fogger DMX fluid reservoir. Fill with fluid, being careful not to overfill reservoir. Replace both caps securely.
- 3) Connect the remote handset supplied with the machine, to the connector which is located on the rear panel.
- 4) Activate the **Mains On** switch located on the rear panel. The Mains On switch will illuminate to indicate the presence of power, the **handset** indicator on the remote handset will also illuminate (or slow flash on startup). If the handset indicator of the remote handset does not illuminate, ensure the connector is properly inserted.
- 5) The **handset** indicator will flash slowly as the machine heats up. The indicator will begin flashing quickly when the fog machine is ready to operate. Fog is available at this point, but full fog output will not be available. After approximately 9 minutes the indicator will be solid when the fog machine has fully heated and is ready for use at full fog output if required.
- 6) It may now be necessary to **prime** fluid into the system to expel any air that might be present. The **Variflow** control on the remote handset should be set to Full position. A dry hose can take between 45 - 60 seconds to prime. This is normal because of the inside diameter of the hose. This only needs to be done if the unit was left to run dry.
- 7) Activating the **Smoke** switch will effect a pulsing fluid flow which will Prime the machine correctly. Once Primed (when there is no more sporadic output) the controls on the remote handset can be set as desired.

Industrial Option Only!

To adjust the depth of the hose, simply loosen Nut 'A' and slide it up or down the hose and retighten. Be careful not to pinch off the flow of fluid.



Note:



In order to prime the fog machine, the handset indicator must be a solid red.

lemaitrefx.com

Remote Handset Operations

1. The fog output time is set using the 'Duration' control. 0 to Max, and the time between successive fog outputs is set using the 'Interval' control. 0 to Max. Continual flow can be achieved if 'Interval' setting is 0 (*Figure 1, Page 7*).

Remote Handset LED Indicator

The Stage Fogger DMX Remote Handset was designed to indicate operation modes. These are as follows:

Slow flashing output: Indicates unit is not ready to operate but still in heating mode, fog is not available at this point.

Quick flashing output: Indicates unit is ready to operate but still in heating mode, some fog is available at this point.

Solid Led: Indicates that the unit is ready to fog at full output.

No Illumination: Problem. Check Remote Handset connection on the rear panel of Stage Fogger DMX. If this fails to correct the problem, contact your local Le Maitre dealer.

Remote and External Control Features

External Remote Connector

The standard Remote Handset cable may be extended from the machine, and operated effectively away from the Stage Fogger DMX. The maximum recommended cable length is 500 Feet.

DMX Operation

The Stage Fogger DMX comes equipped with onboard DMX Control as a standard feature (*Figure 2, Page 7*).

- 1) Plug in the 5 pin DMX cable into the DMX IN connector located on the rear of the Stage Fogger DMX. A terminator may be required if the DMX OUT is not used.
- 2) Select the DMX address assigned to the Stage Fogger DMX by using the DMX ADDRESS thumbwheel selector located on the rear of the Stage Fogger DMX. If a valid DMX signal is available then the Stage Fogger DMX ignores the settings on the standard remote.
- 3) Fog output is varied by the DMX signal. 0% is off and 1% - 100% is fog intensity.
- 4) 15 Amp chassis fuse on the back of the machine.

Remote Handset Image

Figure 1

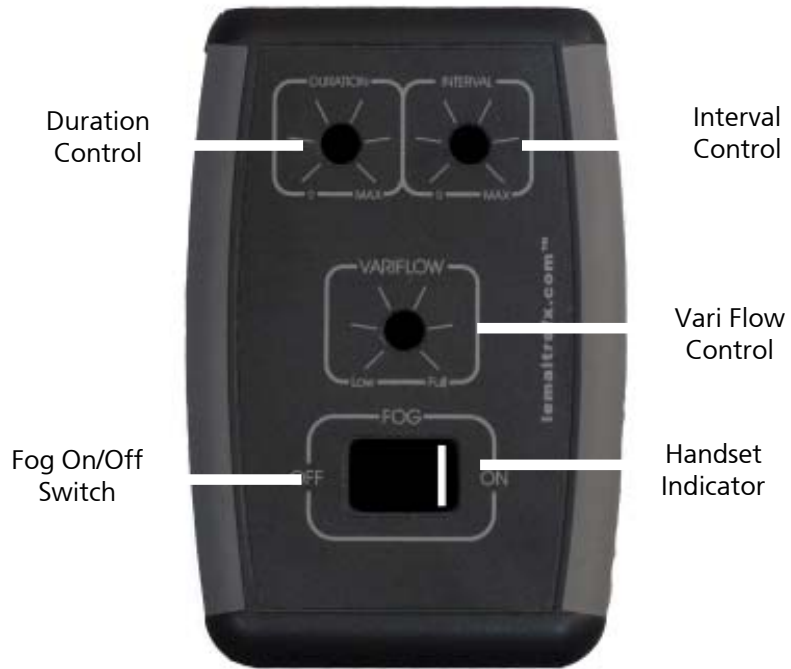

External Connector and DMX Operation

Figure 2



Stage Fogger DMX Tube Change Images

Figure 4

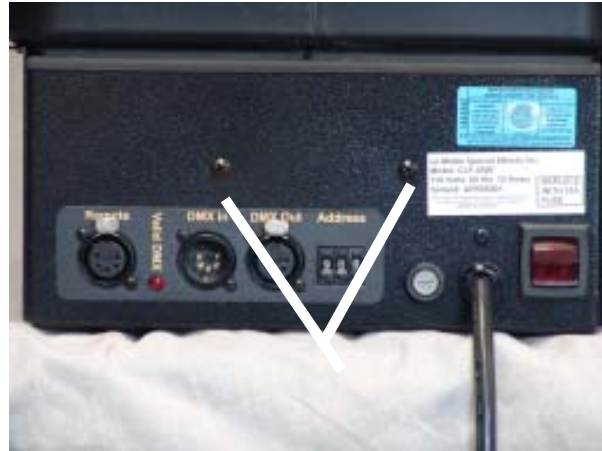
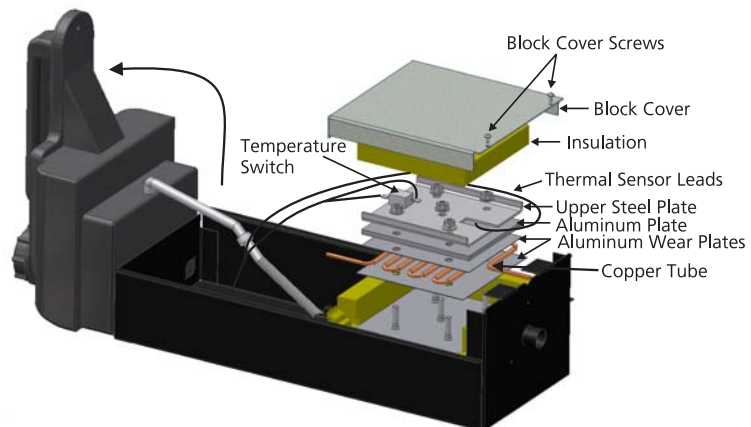

Figure 5



Figure 6



Stage Fogger DMX Tube Change Procedure

The block contains extremely hot surfaces and liquids. These will cause severe burns on contact. Please unplug power to eliminate electrocution hazard and allow the unit to cool before attempting to service the block.

1. Remove the eight screws from the case. Six are under the lip at mid level and two are on top. Slide the upper cover forward and remove it from the machine. Lift the jug up and out of the way (**Figure 3**).
2. Remove the two screws from the front edge of the block cover. Slide the cover backward to release the two back tangs from the lower cover and lift the cover off.
3. Remove the two screws on the rear of the machine in order to remove the protective shield (**Figure 4 & 5, Page 8**).
4. Unfasten the tube by releasing the 7/16" brass nut at the pump. This line may be under significant pressure if the tube was plugged.
5. Be careful not to damage any exposed wiring. Remove the upper steel plate by loosening the five nuts with a 1/2" socket. Gently lift the plate back out of the way leaving the high temperature switch undisturbed.
6. Lift the aluminum plate up cautiously to avoid damage to the Thermal sensor (**Figure 6, Page 8**).
7. Remove the copper tube and two thin aluminum wear plates.

Figure 3



7. When replacing the parts ensure all mating surfaces are flat and clean to promote good thermal conduction. Note that the hole pattern of the plates is not identical. One of the four outer bolts is offset more than the other three. Place the larger wear plate on the block. Place the copper tube on the wear plate. Adjust the runs of tube so they don't touch the bolts. Place the smaller wear plate on and set the heavy aluminum plate on. Next add the upper steel plate while checking that the wires are not pinched or shorted. Move the tube side to side as required to allow the squeezing plates to rest only on the flattened area of the tube.
8. Thread the five nuts and lock washers on finger tight. Check alignment of the layers. Tighten the center bolt down snug with a 1/2" socket. Repeat with the other four bolts. Move to the center bolt and pull tighter by a quarter turn. This will give 5-7 foot pounds of torque. Repeat this on the remaining four bolts.
9. Install top insulation and plug in fog machine and allow to heat up fully. Run fog through the fog machine until it reaches its lowest output. Turn off fog and disconnect power to unit. Remove the upper insulation and allow the unit to cool further (approximately 15 minutes), then all five bolts tighten another 1/2 turn and the thermal couple screw until snug. **Caution: The heat exchanger is still extremely hot, care must be taken not to burn yourself while tightening the bolts.**
10. Replace the upper insulation and cover by inserting the tangs into the slots and slid the cover forward. Fasten the cover down with the two screws.
11. Replace the jug and check the tubing is not pinched or touching the copper tubing.
12. Slide the lid into place and fasten with the eight screws.
13. Plug the machine in and allow it to come to full heat. You are now ready to fog away!

Maintenance

Exterior:

The casing of the Stage Fogger DMX is steel with a powder paint coating. To clean simply wash with mild soap and warm water.

Heat Exchanger

With normal use we do not recommend flushing or cleaning the heat exchanger, with the use of genuine Le Maitre fluids. Using high quality Le Maitre fluid should result in a long heat exchanger life. (See warranty policy later in this manual).

Recommended Fluids

Directors's Choice Fog Fluid: This fluid has been our long standing blend. It is a clean, white, practically odourless fog. It is used for many applications where a cloud of fog is required with a medium hang time.

Pro Beam (Long Lasting) Fog Fluid: We have had many compliments on our fog fluid but many of our customers would like it to hang longer so we introduced the "Long Lasting Fluid". It is still odourless but a little less white than our "Director's Choice". It hangs in the air 2 - 3 times longer than the "Director's Choice".

Quick Dissipating Fog Fluid: We have been mixing this for some time for our special effects people working in the movies. We have decided that there are many other applications for this fluid. When using this in the LSX or LSG, you will find it works very well if you are having problems with the smoke rising too quickly. It has also been used for quick burst-of-steam effects, nitrogen bursts, etc. It will dissipate at about twice the rate of the "Molecular Fluid".

Extra Quick Dissipating Fog Fluid: It is very similar to the "Quick Dissipating" but dissipates at about twice the rate of the "Quick Dissipating".

Molecular Fog Fluid: The "Molecular Fluid" was originally designed for use in the LSG and LSX, however, many other applications were found very quickly. It is clean, white, thick fog, practically odourless and dissipates as it begins to warm.

Maxi Fog Fluid: Maxi Fog Fluid was developed for our high volume users requiring an excellent balance of price and performance without compromise.

EZ Kleen Preventative Maintenance Fluid: EZ Kleen is used as a preventative maintenance measure to ensure longer heat exchanger life. It is easy to use and should be used on a regular basis to prevent blockage of your heat exchanger that frequently happens to fog and haze machines.

All of our Fog Fluids are water based. Permanent damage will occur if Haze Fluid is used in the Power Fog Industrial for any length of time.



Warranty

Warranty:

All warranty is one year parts and labour unless specified and is on manufacturer defect only. Abuse or poor maintenance is not accepted. Le Maitre fluids must always be used. Any trace of other fluids will automatically void **ALL** warranties. Accept no substitutions as there are no exceptions to this rule. Proof of purchase or proof of sale must always accompany any warranty returns. An RA (return authorization) number must be noted on the outside of any box returned to our facilities. Any packages without a clearly marked RA number will not be accepted by our receiving department. Freight on warranty items are freight prepaid to our facility and we will prepay freight back to your facility after repair, by the most economical means available. Should you require the item express-returned, then you are responsible for any difference in freight cost.

Return Policy:

Return of any product must be done within 30 days of purchase. The package must be returned freight prepaid and the RA number clearly marked on the outside of the box. A restocking charge of up to 25% may be levied. Only credits are issued to the dealers account. Any product not returned within 30 days is considered purchased.

Warning:

Le Maitre Special Effects Inc. considers all it's product to be safe for use in the application it was intended. Le Maitre Special Effects takes no responsibility for misuse or incorrect use. Always refer to equipment owners manual for proper use.